

With its performance, versatility, and robustness, the MS-820 has universal appeal to any industry planning to automate or improve bar code tracking.

The MS-820 scanner's capacity to read various bar code densities from 3 to 30 inches makes it the leader in the class of high-speed, fixed-mount industrial scanners. Using advanced technology in decoding, optics, and analog processing, the MS-820 can decode high density labels throughout its scan speed range.

The MS-820's IP65 and heavy industrial rating makes it ideal for applications such as conveyors, assembly lines, or embedding within machinery.

MS-820

INDUSTRIAL BAR CODE SCANNER

Extended Reading: The MS-820 is capable of reading distances between small and large packages. It can read symbols out to 30 inches (76.2 cm) at a 60° scan angle, up to 10 inches (25.4 cm) wide.

IP65 Enclosure: Heavy-duty, die-cast aluminum housing and industrial sealing safeguard the circuitry and optical components from dust and moisture. This makes the MS-820 impervious to the harmful effects of industrial environments.

Downloadable Software: The MS-820 uses flash memory that allows firmware updates to occur onsite.

Real-time Controls: Discrete input/output connections consisting of three optoisolated programmable outputs, one trigger input, and one programmable input provide versatile programming options.

Reverse Video: This feature allows users the flexibility to read light-on-dark or dark-on-light bar codes.

Versatile Mounting: Blind-threaded mounting holes, located on the bottom and top of the scanner, eliminate the need for bulky accessory brackets. This allows the MS-820 to be mounted to any flat surface.



ESP™ Easy Setup Program:

Microscan's ESP™ software is a user friendly, windows-based setup program that gives the user a simplified configuration tool. It is compatible with Windows 95, 98, NT, and 2000.

Symbologies:

Like all Microscan scanners, the MS-820 scans virtually all widely used bar code symbologies, including:

- PDF417
- Code 128
- Code 39
- I 2 of 5
- Codabar
- UPC/EAN
- Code 93

Support Options:

- Installation assistance
- Service agreements
- Training
- On-site support
- Extended warranty



Noise Protection: Fully shielded circuitry protects the MS-820 from the invasion of electrical fast transients (EFT), electrical static discharge (ESD), and radio frequency interference (RF). Signal integrity is assured with circuitry specifications designed to International Electrotechnical Commission (IEC) standards of 801-4 Level 4 for EFT and 801-2 Level 4 for ESD.

MS-820 INDUSTRIAL BAR CODE SCANNER

SPECIFICATIONS/OPTIONS

MECHANICAL

Depth: 2.59" (6.58 cm)
Width: 3.47" (8.81 cm)
Height: 1.38" (3.50 cm)
Weight: 7.5 oz. (212 g)

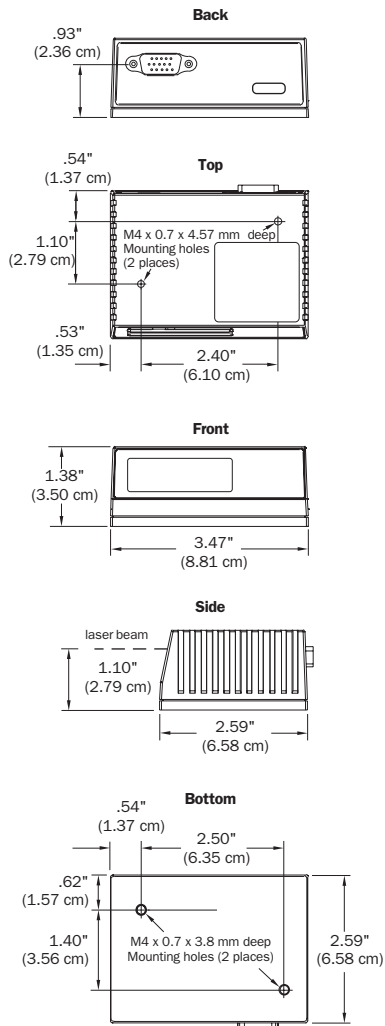

ENVIRONMENTAL

Enclosure: die-cast aluminum, IP65 rated
Operating temperature: 0° to 50° C (32° to 122° F)
Storage Temperature: -50° to 75° C (-58° to 167° F)
Humidity: Up to 90% (non-condensing)
Ambient light immunity:
 • 450 foot candles (indoor: fluorescent, incandescent, mercury vapor, sodium vapor)
 • 1800 foot candles (soft outdoors)

EMISSIONS

Heavy industrial: EN 61000-6-2:1999
Radiated emission: EN 55022:1998 Class A 30-1000 MHz
Conducted emissions: EN 55022:1998 Class A .15-30 MHz

LASER LIGHT

Type: Laser diode
Output wavelength: 650 nm nominal
 Infrared Option: 780 nm nominal (MS-825)
Operating life: 50,000 hours @ 25°C
Safety class:
 • Visible laser: CDRH Class II, 650 nm
 • Infrared laser: CDRH Class I, 780 nm

LOW DENSITY RANGE DATA

| Narrow-bar-width | Read Range | Read Range Scan Width |
|------------------|----------------------------|------------------------------|
| .0075" (.002 mm) | 10 to 12" (25 to 30.5 cm) | N/A |
| .010" (.254 mm) | 7 to 16" (17.8 to 40.6 cm) | 10" at 12" (25.4 at 30.5 cm) |
| .015" (.381 mm) | 6 to 19" (15.2 to 48.3 cm) | N/A |
| .020" (.508 mm) | 5 to 22" (12.7 to 55.8 cm) | N/A |
| .040" (1.02 mm) | 4 to 30" (10.2 to 76.2 cm) | N/A |

HIGH DENSITY RANGE DATA

| Narrow-bar-width | Read Range | Read Range Scan Width |
|------------------|--------------------------------|------------------------------|
| .0033" (.084 mm) | Call Microscan | N/A |
| .005" (.127 mm) | 4" to 5.5" (10.2 to 14 cm) | 4" at 4.5" (10.2 at 11.4 cm) |
| .0075" (.191 mm) | 3.5" to 6.75" (8.9 to 17.1 cm) | 5" at 4.5" (12.7 at 11.4 cm) |
| .010" (.254 mm) | 3.25" to 8" (8.2 to 20.3 cm) | N/A |
| .015" (.381 mm) | 3" to 9" (7.6 to 22.9 cm) | N/A |

*Ranges based on a Grade A, Code 39 label. If your read range falls outside the above ranges, please call Microscan.

SCANNING PARAMETERS

Mirror type: Rotating, 10-faceted
Optional raster mirror image: 10 raster scan lines over a 2-degree arc (or 0.500 inch raster height at 8-inch (20.3 cm) distance).
Scan rate: Adjustable from 350 to 1100 scans/second, default=400
Scan width angle: Typically 60°
Pitch: ±50° maximum
Skew: ±40° maximum
Label contrast: 25% min. absolute dark to light differential at 650 nm wavelength.

COMMUNICATION INTERFACE

Interface: RS-232/422/485
Optional Interface Boxes: available for DeviceNet and Ethernet.

PROTOCOLS

Point-to-Point • Point-to-Point w/RTS/CTS • Point-to-Point w/XON/XOFF • Point-to-Point w/RTS/CTS & XON/XOFF • Polling Mode D • Multidrop • Daisy Chain • User Defined • User Defined Multidrop

CODE TYPES

Standard offering: Code 39, Codabar, Code 93, Interleaved 2 of 5, Code 128, and PDF417.
Applications Standards: UCC/EAN-128, AIAG

HOST CONNECTOR PIN ASSIGNMENTS

| Pin No. | Host RS232 | Host/Aux RS232 | Host RS422/485 | In/Out |
|---------|------------------------------------|----------------|----------------|--------|
| 1 | Power +10 to 28 VDC | | | In |
| 2 | Host TxD | Host TxD | TxD(-) | Out |
| 3 | Host RxD | Host RxD | RxD(-) | In |
| 4 | Power/Signal Ground | | | |
| 5 | Trigger (-) | | | In |
| 6 | RTS | Aux TxD | TxD(+) | Out |
| 7 | Output 1 (+) | | | Out |
| 8 | Default configuration ^a | | | In |
| 9 | Trigger (+) | | | In |
| 10 | CTS | Aux RxD | RxD (+) | In |
| 11 | Output 3 (+) | | | In |
| 12 | New Master | | | In |
| 13 | Chassis ground ^b | | | |
| 14 | Output 2 (+) | | | Out |
| 15 | Outputs 1,2,3 (-) | | | Out |

a. The default is activated by connecting pin 8 to ground pin 4.
 b. Chassis ground: Used to connect chassis body to earth ground only. Not to be used as power or signal return.

CONNECTOR

Type: 15-pin high density D-subminiature plug

ELECTRICAL

Power requirement: 10–28 VDC, 200 mA p-p max ripple, 120mA at 24 VDC (typ.)

DISCRETE I/O

Trigger Input: Optoisolated, 4.5–28V rated, (12 mA at 24 VDC)
New Master Input: Optoisolated, 4.5–28V rated, (12 mA at 24 VDC), New Master (-) to signal ground
Outputs (1, 2 & 3): Opto-isolated, 1–28V rated, (I_{CE} <100 mA at 24 VDC, current limited by user)

SAFETY CERTIFICATIONS

CDRH, FCC, UL/cUL, TÜV, CE, BSMI

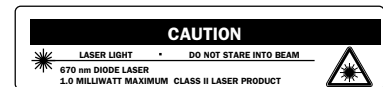

ISO 9001/Cert. No. 00-1047

©2001 Microscan Systems, Inc. 10/01
 Specifications subject to change.

Product specifications are given for typical performance at 25°C (77 °F) using grade A labels. Some performance characteristics may vary at high temperatures or other environmental extremes.

Warranty—One year limited warranty on parts and labor. Extended warranty available.

MICROSCAN®

Microscan Systems, Inc.
 Tel 425 226 5700 / 800 251 7711
 Fax 425 226 8250
Microscan Europe
 Tel 31 172 423360 / Fax 31 172 423366
Microscan Asia Pacific R.O.
 Tel 65 846 1214 / Fax 65 846 4641

Part of a full range of sales tools available from our web site:

www.microscan.com
 E-mail: helpdesk@microscan.com